

MANDATORY SERVICE BULLETIN

NUMBER: SB11-08
REVISION: 00
DATE: 06/24/2011

SUBJECT: SPAR PASS-THRU HOLE AND TAILCONE MODIFICATION

EFFECTIVITY:

KODIAK 100 Series Aircraft Serial Numbers: 100-0001 through 100-0045.

SUMMARY:

It has been determined that the mount design of the vertical tail leaves two uncovered areas in the top of the fuselage that allows fluid entry into the area AFT of the rear interior bulkhead. This fluid does not adequately drain, and has a potential to negatively affect some of the electronics.

ACTION:

Quest is mandating the installation of a sealant over the area indicated in **Figure 1-1**, as well as the installation of two (2) drain grommets on the underside of the tailcone.

NOTE: Any time maintenance is performed which requires the removal of the vertical tail, the instructions within this Service Bulletin should be complied with.

COMPLIANCE:

This Mandatory Service Bulletin must be complied with on or before the next 100 hour, Annual Inspection, or scheduled maintenance, whichever comes first.

LOG OF CHANGES:

Revision:	Date:	Description of Change:
00	06/24/2011	Initial Release

ATTACHED DOCUMENTS:

Document #:	Date:	Document Title:
N/A	N/A	N/A

PARTS, TOOLS, AND EQUIPMENT:

The parts, tools and equipment listed below are needed in order to complete the instructions contained within.

Parts and Tools included in this Service Bulletin:

Item	Quantity	Part Number	Description
1	2	AN231-4	Drain Grommet

Parts and Tools **Not** included in this Service Bulletin:

Item	Quantity	Part Number	Description
1	AR	Commercially Available	Pro-Seal® 890 (Class B-2)
2	AR	Loctite® 7387	Activator
3	AR	Loctite® 330	Adhesive

Quest Aircraft Company, LLC
 © Copyright 2011
 All Rights Reserved

No part of this document may be reproduced, copied, transmitted, disseminated, downloaded or stored in any storage medium, for any purpose without the express prior written consent of Quest Aircraft Company, LLC.

MANDATORY SERVICE BULLETIN

MANDATORY SERVICE BULLETIN

MANDATORY SERVICE BULLETIN

NUMBER: SB11-08

REVISION: 00

DATE: 06/24/2011

SUBJECT: SPAR PASS-THRU HOLE AND TAILCONE MODIFICATION

FAA APPROVED:

The modification described in this Mandatory Service Bulletin has shown compliance with the applicable Federal Aviation Regulations and is FAA Approved.

INDUSTRY SUPPORT INFORMATION:

N/A

WEIGHT AND BALANCE:

Negligible

MANPOWER:

The instructions contained in this Mandatory Service Bulletin will take approximately:

- 1.5 Hours

CREDIT AND WARRANTY INFORMATION:

Quest Aircraft Company will reimburse for the cost of this modification up to \$112.50 for aircraft still under factory warranty. For reimbursement send Quest Aircraft Company a copy of the modification record and serial number of the aircraft on which the modification was completed.

Quest Customer Service

Service Bulletin SB11-08

Phone: (208)263-1111 Toll Free: 1(866)263-1112

Email: Customercare@questaircraft.com

COMPLETION:

Record the work performed in the *KODIAK 100 Maintenance Records*.

ACCOMPLISHMENT INSTRUCTIONS:

Accomplishment Instructions are listed in the next section of this Service Bulletin.

ATTACHED DOCUMENTS:

N/A

SPECIAL INSTRUCTIONS:

N/A

MANDATORY SERVICE BULLETIN

MANDATORY SERVICE BULLETIN

1. AIRCRAFT PREPARATION

1. Remove the AFT bulkhead from the aircraft as shown in the KODIAK 100 Maintenance Manual (P/N **490770**).
2. Clean the interior and exterior surfaces around the spar pass-thru holes shown in **Figure 1-1** using a lint-free cloth and denatured alcohol or equivalent.
3. Apply masking tape to the inside surface of the aircraft skin covering the spar pass-thru holes shown in **Figure 1-1**.

2. SEALANT APPLICATION

1. Apply ProSeal® (P/N **P/S 890 B-2**) into the spar pass-thru holes shown in **Figure 1-1** on both sides of the aircraft. Ensure the sealant adheres around the perimeter of the holes and is faired to the upper surface of the aircraft skin with a 0.06" to 0.13" overlap over the edges of the hole.
2. Follow all manufacture's safety and cure time instructions.
3. Remove the masking tape applied to the inside surface of the aircraft skin.
4. Reinstall the AFT bulkhead into the aircraft as shown in the KODIAK 100 Maintenance Manual (P/N **490770**).

3. TAILCONE MODIFICATION

1. Remove the twenty eight (28) screws securing the tailcone (P/N **100-250-0097**) to the aft fuselage and remove the tailcone (P/N **100-250-0097**) from the aircraft.
2. Disconnect the electrical connection to the tailcone navigation light.
3. Mark and drill the drain holes as indicated in **Figure 1-2, Detail B**.
4. Apply Loctite® activator (P/N **7387**) to the bonding surfaces of the tailcone (P/N **100-250-0097**) and the two (2) drain grommets (P/N **AN231-4**).
5. Apply Loctite® adhesive (P/N **330**) and center the two (2) drain grommets (P/N **AN231-4**) over the two (2) drain holes with the exit port facing aft as shown in **Figure 1-2, Detail B**.
6. Follow manufacturer's safety and cure time instructions.
7. Position and secure the tailcone (P/N **100-250-0097**) using the twenty eight (28) screws and connect the navigation light.

4. RECORD WORK PERFORMED IN KODIAK LOG BOOKS

Upon completion, record all work performed in the appropriate KODIAK maintenance records.

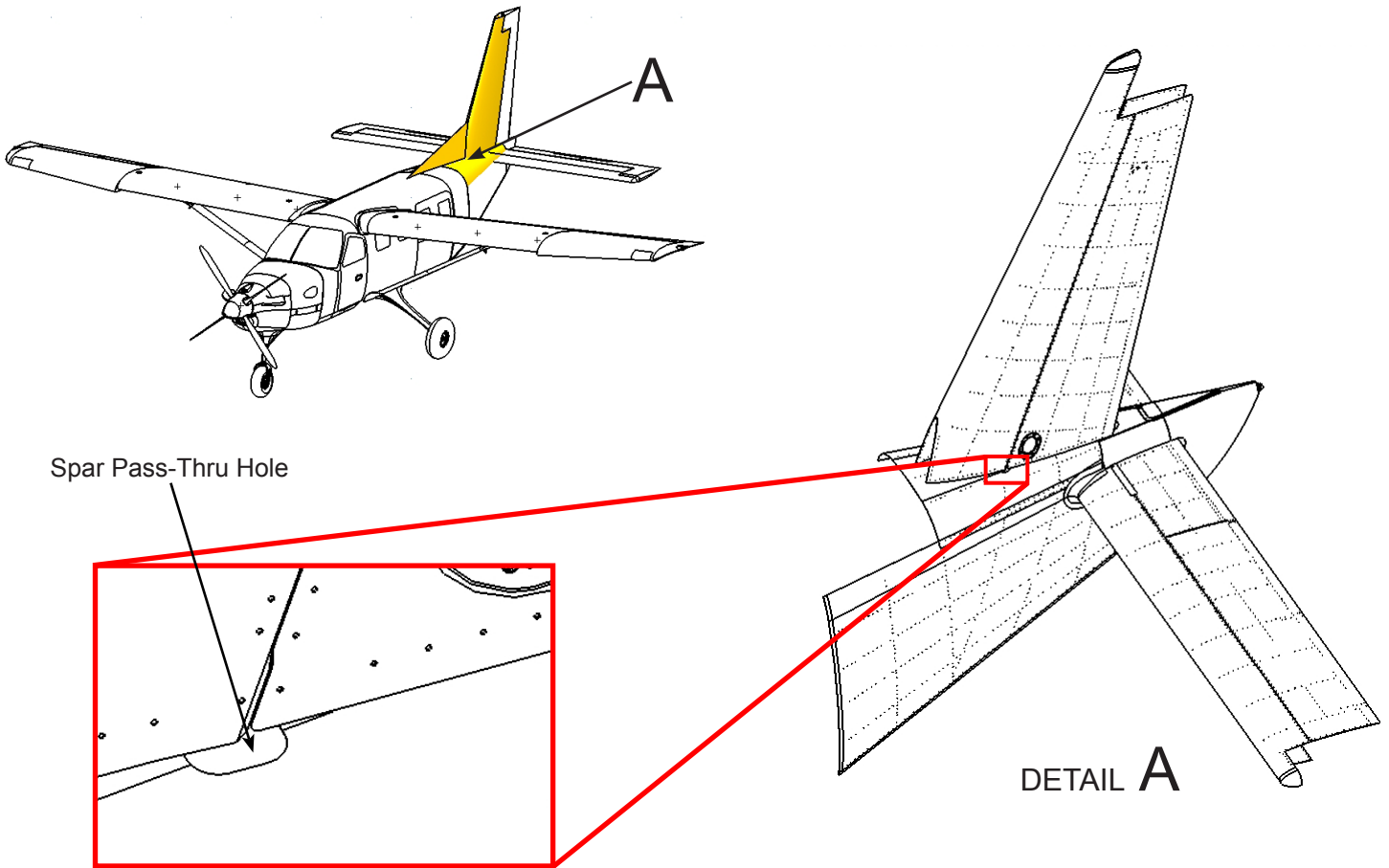

DETAIL B

Completed Sealant Installation

 **NOTE:** Verify that the existing X1010 edge trim on the vertical stabilizer skin is adhered to the skin and in good condition.

 **NOTE:** Sealant application should be mirrored on the right side of the aircraft.

Figure 1-1: Spar Pass-Thru Hole Modification

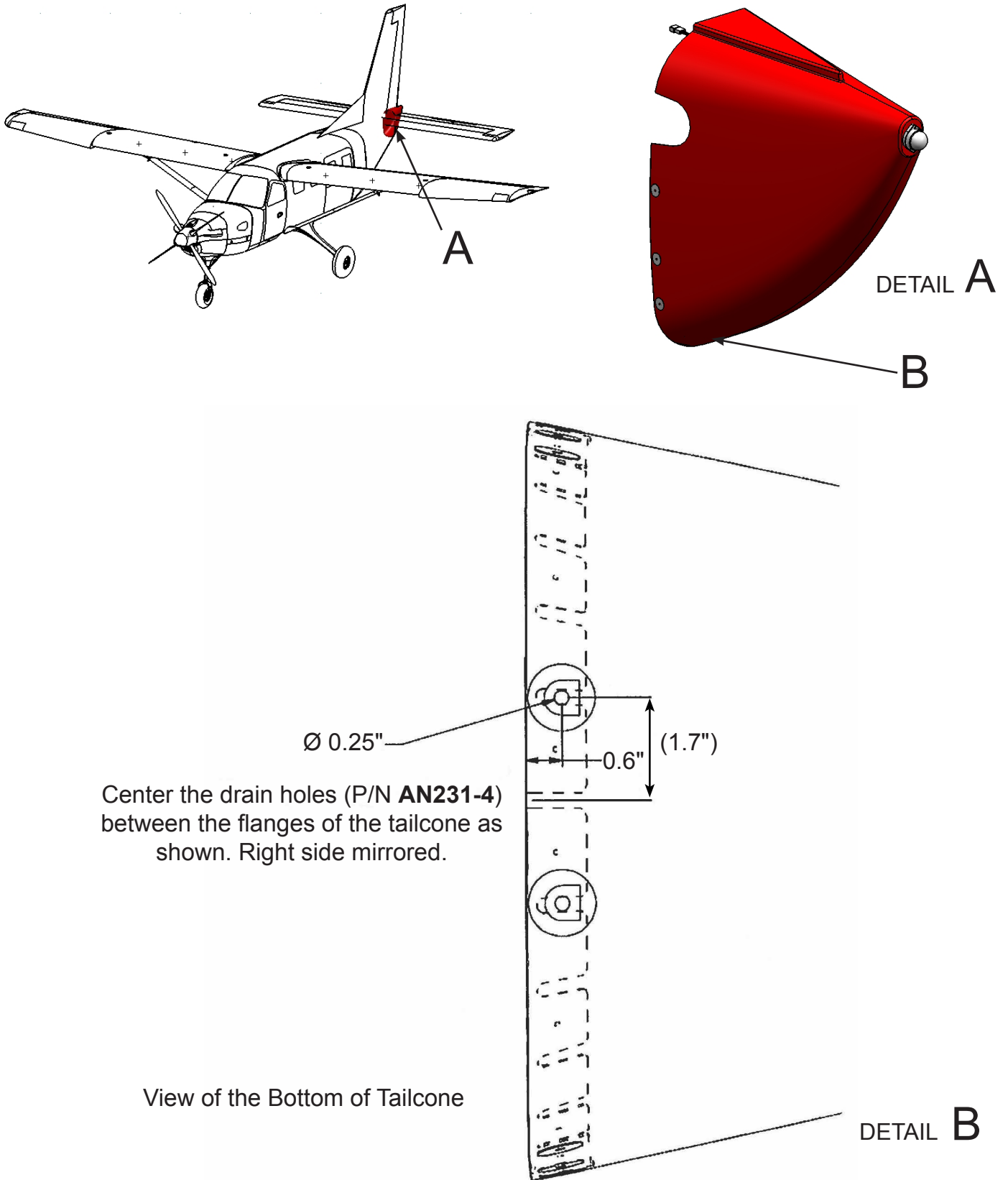

Figure 1-2: Tailcone Modification