

MANDATORY SERVICE BULLETIN

NUMBER: SB11-02

REVISION: 01

DATE: 02/17/2011

SUBJECT: RUDDER TRIM MOTOR SERVICING

EFFECTIVITY:

KODIAK 100 Series Aircraft Serial Numbers: 100-001 through 100-046

SUMMARY:

Quest has received a single report of the screws securing the rudder trim motor to the small gearbox loosening during normal operations. This Mandatory Service Bulletin describes accessing the securing screws and applying a thread fastening/sealing agent.

ACTION:

Quest is mandating a one time application of a thread fastening/sealing agent to the securing screws of the rudder trim motor. Refer to **Figure 1-1** and **Figure 1-2**.

LOG OF CHANGES:

Revision:	Date:	Description of Change:
00	02/09/2011	Initial Release
01	02/17/2011	General formatting throughout the entire document Clarification: Compliance information updated. Added: Directions for aligning the set screw with the opening on the housing.

ATTACHED DOCUMENTS:

Document #:	Date:	Document Title:
N/A	N/A	N/A

PARTS, TOOLS, AND EQUIPMENT:

The parts, tools and equipment listed below are needed in order to complete the instructions contained within.

Parts and Tools included in this Service Bulletin:

Item	Quantity	Part Number	Description
N/A	N/A	N/A	N/A

 Parts and Tools **Not** included in this Service Bulletin:

Item	Quantity	Part Number	Description
1	-	Loctite242®	Thread fastener/sealer (Blue)
2	-	Permatex 834-300®	Thread fastener/sealer (Blue)

NOTE: Either item 1 or item 2 are acceptable to conduct the work presented in this Service Bulletin. Refer to the instructions listed below for further details.

Quest Aircraft Company, LLC
 © Copyright 2011
 All Rights Reserved

No part of this document may be reproduced, copied, transmitted, disseminated, downloaded or stored in any storage medium, for any purpose without the express prior written consent of Quest Aircraft Company, LLC.

MANDATORY SERVICE BULLETIN

NUMBER: SB11-02

REVISION: 01

DATE: 02/17/2011

SUBJECT: RUDDER TRIM MOTOR SERVICING

FAA APPROVED:

The inspection and modification described in this Mandatory Service Bulletin has shown compliance with the applicable Federal Aviation Regulations and is FAA Approved.

COMPLIANCE:

This Mandatory Service Bulletin must be complied with on or before the next 100 hr, Annual Inspection or scheduled maintenance, whichever comes first.

INDUSTRY SUPPORT INFORMATION:

N/A

WEIGHT AND BALANCE:

Negligible

CREDIT AND WARRANTY INFORMATION:

N/A

Quest Customer Service

Service Bulletin SB11-02

Phone: (208)263-1111 Toll Free: 1(866)263-1112

Email: Customercare@questaircraft.com

COMPLETION:

Record the work performed in the **KODIAK 100 Maintenance Records**.

ACCOMPLISHMENT INSTRUCTIONS:

Accomplishment Instructions are listed in the next section of this Service Bulletin.

MANPOWER:

The instructions contained in this Mandatory Service Bulletin will take approximately:

- 1 hour

ATTACHED DOCUMENTS:

N/A

MANDATORY SERVICE BULLETIN

MANDATORY SERVICE BULLETIN

1. RUDDER TRIM MOTOR SERVICING INSTRUCTIONS

1.1 REMOVAL OF RUDDER TRIM MOTOR COMPONENTS

- 1.1.1. Disconnect the electrical connection located at the top of the rudder trim motor assembly.
- 1.1.2. Remove the four (4) screws (Item 1), four (4) nuts (Item 2) and four (4) washers (Item 3) securing the electrical receptacle to the rudder trim motor bracket (Item 4), and carefully set aside the electrical receptacle. Refer to **Figure 1-1, Detail B. and Table 1-1.**
- 1.1.3. Reconnect the electrical connection to the electrical receptacle providing power to the rudder trim motor. Using the rudder trim switch located on the control pedestal, align the rudder trim pinion drive motor (Item 11) to allow access to the set screw (Item 12). Refer to **Figure 1-1, Detail D.**



NOTE: For aligning the rudder trim pinion drive motor, a light and mirror are suggested.

- 1.1.4. Disconnect the electrical connection from the electrical receptacle.
- 1.1.5. Remove the four (4) bolts (Item 5), four (4) nuts (Item 6) and four (4) washers (Item 7) securing the rudder trim gearbox cover plate (Item 8). Refer to **Figure 1-1, Detail C.**
- 1.1.6. Remove the snap ring (Item 9) and thrust bearing (Item 10) securing the rudder trim gearbox cover plate (Item 8) to the pinion drive motor (Item 11), and remove the rudder trim gearbox cover plate (Item 8). Refer to **Figure 1-1, Detail C.**
- 1.1.7. Remove the set screw (Item 12) securing the pinion drive motor (Item 11) to the small gearbox (Item 13), and remove the rudder trim pinion drive motor (Item 11). Refer to **Figure 1-1, Detail D.**
- 1.1.8. Remove the three (3) screws (Item 14 - metric screw) and three (3) washers (Item 15) securing the small gearbox (Item 13) to the mounting bracket (Item 4), and remove the small gearbox (Item 13). Refer to **Figure 1-1, Detail E.**

1.2 RUDDER TRIM MOTOR SERVICING



NOTE: The thread/sealing agent described below shall be one of the items listed on page 1 of this Service Bulletin.

- 1.2.1. Individually remove the three (3) screws (Item 16) securing the small gearbox (Item 13) to the motor (Item 17), apply a thread fastening/sealing agent, and reinstall the screw (Item 16) before proceeding to the next screw. Tighten the screws (Item 16) to finger tightness + 1/4 turn, approximately .5 in-lb. Refer to **Figure 1-2.**

- 1.2.2. Apply a thread fastening/sealing agent to the three (3) screws (Item 14 - metric screw). Position the small gearbox (Item 13) and secure using the three (3) screws (Item 14 - metric screw) and three (3) washers (Item 15). Refer to **Figure 1-1, Detail E**.
- 1.2.3. Reinstall the pinion drive motor (Item 11) to the small gearbox (Item 13) and ensure the gears mesh well. Apply a thread fastening/sealing agent, to the set screw (Item 12) and secure. Refer to **Figure 1-1, Detail D**.
- 1.2.4. Position the rudder trim gearbox cover plate (Item 8) and secure using the four (4) bolts (Item 5), four (4) nuts (Item 6) and four (4) washers (Item 7). Refer to **Figure 1-1, Detail C**.
- 1.2.5. Reinstall the thrust bearing (Item 10) and the snap ring (Item 9), securing the rudder trim gearbox cover plate (Item 8) to the pinion drive motor (Item 11). Refer to **Figure 1-1, Detail C**.
- 1.2.6. Position the electrical receptacle and secure using the four (4) screws (Item 1), four (4) nuts (Item 2) and four (4) washers (Item 3). Refer to **Figure 1-1, Detail B**.
- 1.2.7. Reconnect the electrical connection located at the top of the rudder trim motor assembly.
- 1.2.8. Perform an operational test on the rudder trim system. Refer to the **KODIAK 100 Maintenance Manual, Chapter 27: Rudder Trim Rigging**.

 **NOTE:** Refer to the **KODIAK 100 Maintenance Manual, Chapter 20 Standard Practices** for torque specifications.

2. RECORD WORK PERFORMED IN KODIAK LOG BOOKS

Upon completion, record all work performed in the appropriate KODIAK maintenance records.

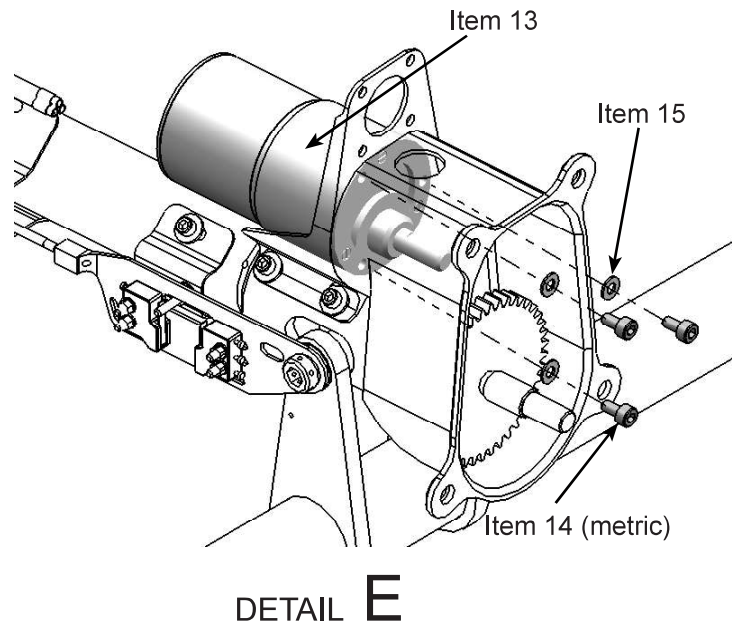
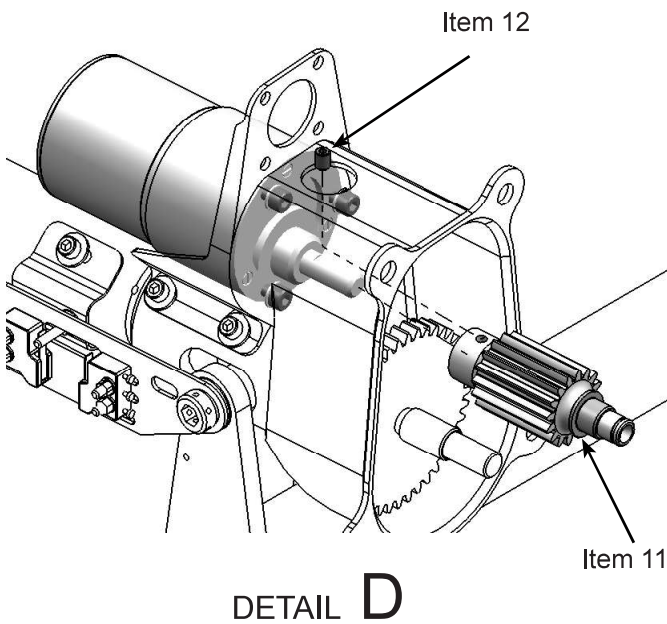
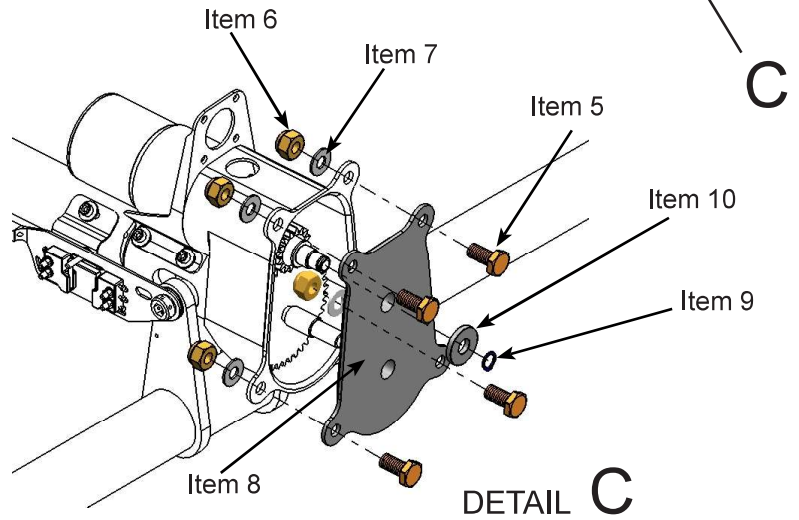
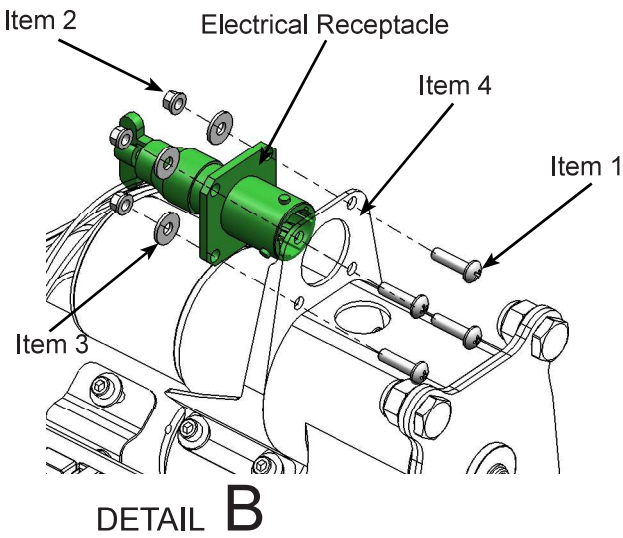
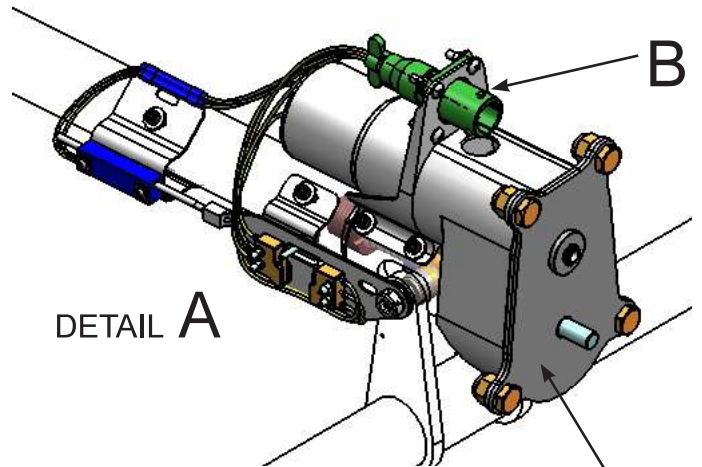
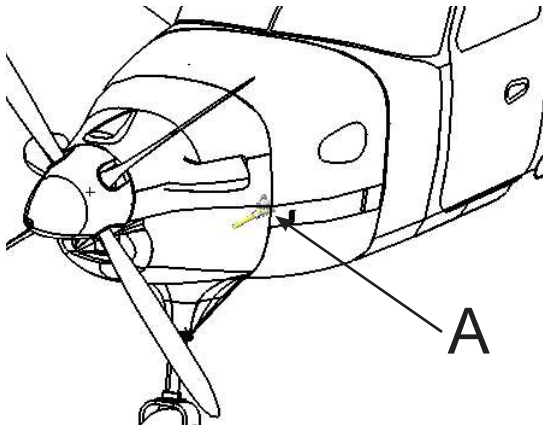

Figure 1-1: Rudder Trim Motor Access

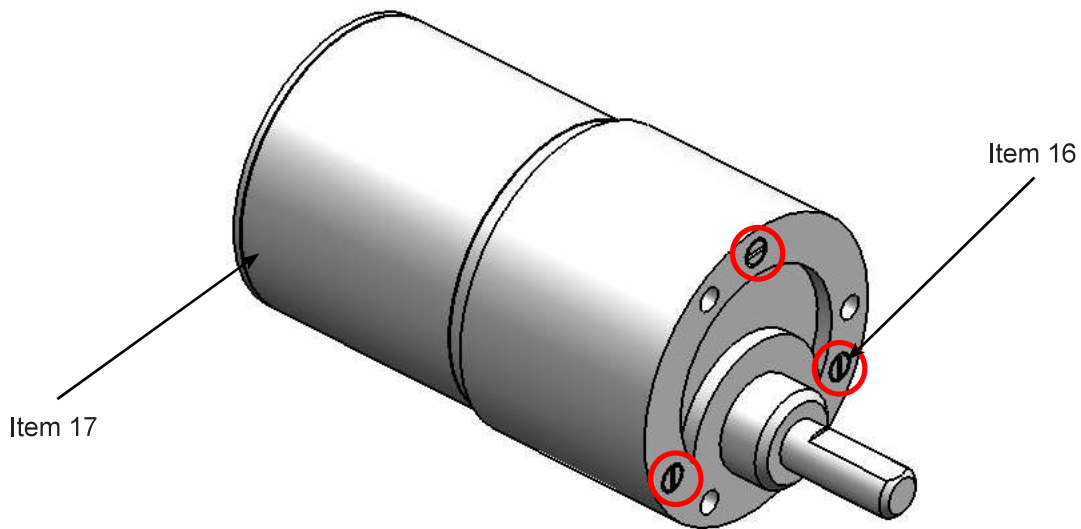

Figure 1-2: Rudder Trim Motor Servicing

Table 1-1: Item Identification

Item Number	Part Number	Description
1	MS51957-16	Screw
2	MS21042-04 or MS21042L04	Nut
3	NAS1149CN432R	Washer
4	100-617-2176	Rudder Trim Motor Bracket
5	AN3-3A	Bolt
6	MS21044N3	Nut
7	NAS1149F0332P	Washer
8	100-617-2183-D01	Gearbox Cover Plate
9	MS16624-1025	Snap Ring
10	MTI-04	Thrust Bearing
11	100-617-2177	Pinion Drive Motor
12	MS51965-112	Set Screw
13	100-820-6175**	Small Gearbox
14	NA0274-030006	Screw (metric)
15	MS15795-803	Washer
16	N/A	Screw
17	100-820-6175**	Motor

NOTE: Part 100-820-6175 is stocked and sold as one assembly (small gearbox and motor).